

# Nozzle



NOZZLE BY **BMS**<sup>®</sup>



MADE IN FRANCE

# Discover our Range of Nozzles

Our range of high-performance nozzle is designed to meet the demands of high-temperature applications, especially where space constraints prevent the use of traditional heating systems. From standard immersion nozzle to customized spiral-heated solutions, we provide reliable and efficient heating for tooling and molding processes. Each model is engineered for durability, optimal heat transfer, and ease of integration into your existing setup.

## Removable Tip Nozzles

p. 3



## Nozzle Tips

p. 5



## Internally heated Nozzles

p. 15



## Mixing Nozzles

p. 18

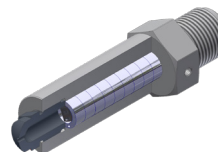

## Filtration Nozzles

p. 24



## Shut-off Nozzles

p. 32

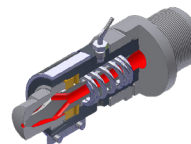

## OEM Nozzle Tips

p. 38



## Solid Nozzles

p. 41



## Adaptators

p. 43



## Removable tip nozzles

Significant savings compared to traditional monobloc nozzle  
 Replaceable tip nozzle with a machined rear thread to fit your machine and a standard 7/8"-14 female front thread to accept standard interchangeable tips.

Designed to replace monoblock nozzle: only replace the tip when it's damaged or when changing molds.  
 Precisely machined on CNC equipment and mirror-polished for optimal flow.  
 Nozzle are available in all lengths and can be supplied with 4 different tip lengths for applications with limited space.

Tips are also available in Cupro-Nickel for improved heat transfer.

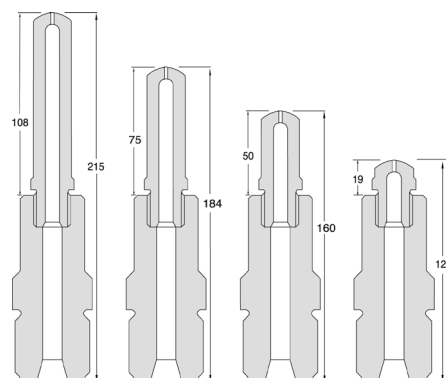
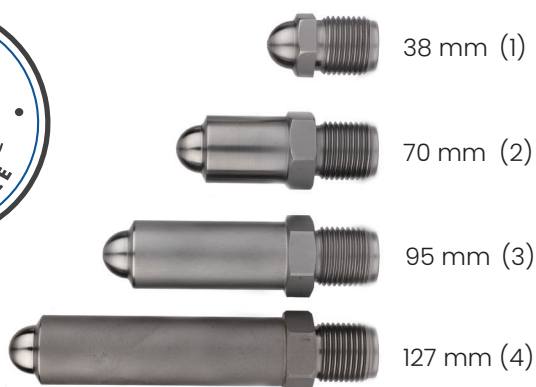

Removable Nozzle with different tips length

### 3 different types of tips:

#### Universal (GP)

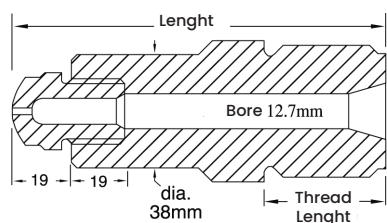

- Standard free-flow design. Minimal flow resistance and minimal back pressure
- Standard flow section  $\varnothing$  12.7 mm, unless otherwise specified.

#### Polyamid (NRT)

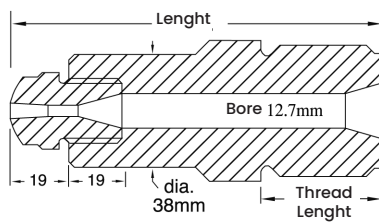

- For use with polyamides, acrylics, and other expensive, heat-sensitive materials.
- The material flows through a 3 mm channel and then into an inverted cone. The sprue breaks inside the tip, reducing flash.

#### ABS (ABS)

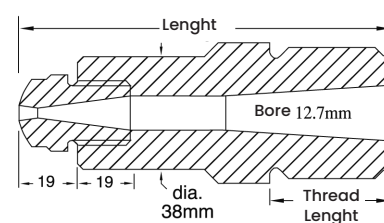

- For use with ABS, PVC, and other viscous materials.
- Reduces heat buildup and material retention zones.
- We recommend large openings to minimize flow resistance. Features a 75 mm long cone from the rear opening zone, with a 12.7 mm long internal channel.

# Removable tip nozzles

## Order form

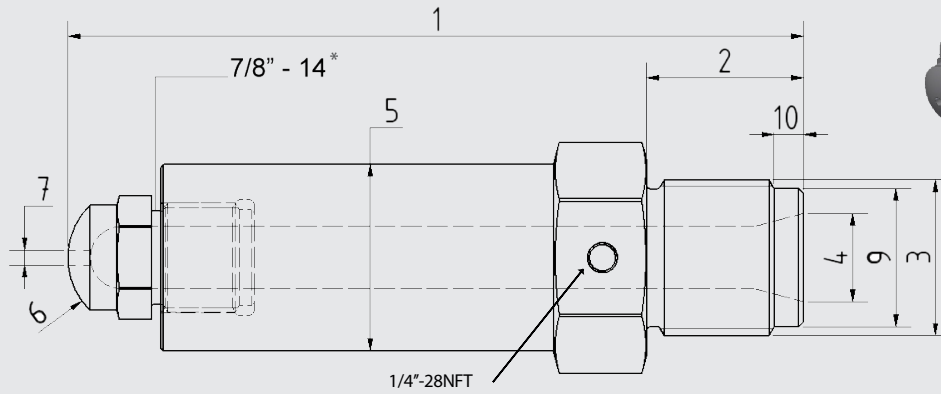
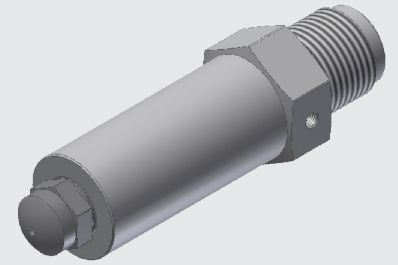

Machine and Model  Injection rate in cm<sup>3</sup>/s

(1) Total length	<input type="text"/>	(7) Opening (1.5, 2.5, 3, 4,...)	<input type="text"/>
(2) Thread Length	<input type="text"/>	(8) Internal Design	<input type="text"/>
(3) Thread Type (M36x2 or 1"1/4-12UNF,...)	<input type="text"/>	<input type="checkbox"/> Universal (GP)	
		<input type="checkbox"/> Polyamid (NRT)	
		<input type="checkbox"/> ABS (ABS)	
(4) Rear opening	<input type="text"/>	(9) Ø relief	<input type="text"/>
(5) Body diameter (30, 38, ...)	<input type="text"/>	(10) Relief length	<input type="text"/>
(6) Radius	<input type="text"/>		

\*Autres sur demande

<p>(8) Type</p> <p><input type="checkbox"/> Universal (GP)   <input type="checkbox"/> Polyamid (NRT)   <input type="checkbox"/> ABS (ABS)</p> <p>ABS &amp; NRT : Opening mini : 3mm</p>	<p>Tip length</p> <p><input type="checkbox"/> 38 mm (1)</p> <p><input type="checkbox"/> 70 mm (2)</p> <p><input type="checkbox"/> 95 mm (3)</p> <p><input type="checkbox"/> 127 mm (4)</p> <p>Length 70, 95 &amp; 127mm are not available in ABS version</p>	<p>(6) Radius</p> <p><input type="checkbox"/> 35 mm (8)</p> <p><input type="checkbox"/> 30 mm (R30)</p> <p><input type="checkbox"/> 19 mm (7)</p> <p><input type="checkbox"/> 15 mm (6)</p> <p><input type="checkbox"/> 12,7 mm (5)</p> <p><input type="checkbox"/> 10 mm (R10)</p> <p><input type="checkbox"/> 9 mm (9)</p> <p><input type="checkbox"/> 120° (4)</p> <p><input type="checkbox"/> 90° (3)</p> <p><input type="checkbox"/> 70° (1)</p> <p><input type="checkbox"/> 60° (2)</p> <p><input type="checkbox"/> Other <input type="text"/></p>	<p>(7) Opening</p> <p><input type="checkbox"/> 1,5 mm (I)</p> <p><input type="checkbox"/> 2 mm (H)</p> <p><input type="checkbox"/> 2,5 mm (J)</p> <p><input type="checkbox"/> 3 mm (K)</p> <p><input type="checkbox"/> 4 mm (L)</p> <p><input type="checkbox"/> 5 mm (M)</p> <p><input type="checkbox"/> 5,5 mm (Q)</p> <p><input type="checkbox"/> 6 mm (N)</p> <p><input type="checkbox"/> 6,5 mm (R)</p> <p><input type="checkbox"/> 7 mm (S)</p> <p><input type="checkbox"/> 8 mm (O)</p> <p><input type="checkbox"/> 9,5 mm (P)</p> <p><input type="checkbox"/> Other <input type="text"/></p>
---	--	--	---

Example: GP16K  
 Universal type (GP) - Tip length 38mm (1) - Radius 15mm (6) - Opening 3 mm (K)

## Removable Nozzle Tips Steel & Cupro-Nickel

Significant savings compared to traditional monobloc nozzle  
Replaceable tip nozzle with a machined rear thread to fit your machine and a standard 7/8"-14 female front thread to accept standard interchangeable tips.

Designed to replace monoblock nozzle: only replace the tip when it's damaged or when changing molds.

Precisely machined on CNC equipment and mirror-polished for optimal flow.  
Nozzle are available in all lengths and can be supplied with 4 different tip lengths for applications with limited space.

Tips are also available in Cupro-Nickel for improved heat transfer.



Length (mm)	Type	High-strength alloy steel	Cupro-nickel
38	Universal	GP1	BGP1
38	Nylon	NRT1	BNR1
38	ABS	ABS1	BABS1
70	Universal	GP2	BGP2
70	Nylon	NRT2	BNRT2
95	Universal	GP3	BGP3
95	Nylon	NRT3	BNRT3
127	Universal	GP4	-
127	Nylon	NRT4	-

*Note: Please ensure the nozzle tips are properly tightened when delivered pre-mounted!*

Excellent thermal transfer properties, making them ideal for applications where maintaining a high temperature at the nozzle tip is crucial or when the use of a band heater is not possible.

Two grades of Cu-Ni are available to offer you the most suitable solution.  
Please contact our sales team: they will assess your application constraints and recommend the best option.

NOTE: Use NRT type for a minimum orifice of 3 mm.

## For the assembly of nozzle, adaptators, tips, ...



**MICA NOZZLE BAND HEATERS**

Waterproof design with brazed connections to prevent material infiltration and extend service life.



**THERMOCOUPLE TYPE NA**

All BMS nozzle are supplied with a threaded flat for these cost-effective thermocouples with a 1/4"-28 NPT sheath.



**SPANNERS**

Ideal for nozzle installation and Removable.



**MOULDPRO COPPER ANTI-SEIZE MCS500**

Copper-based lubricant for smooth assembly of threaded parts, ensuring accurate torque and preventing seizing

Available on  
**mouldshop**

# Removable Nozzle Tips

## Order form

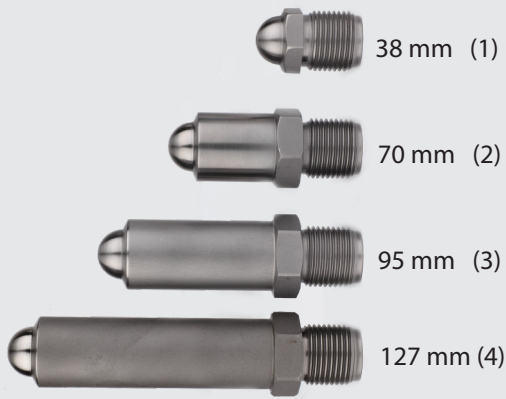

### Type

Universal (GP)

Polyamid (NRT)

ABS (ABS)

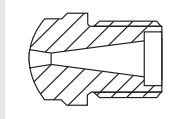
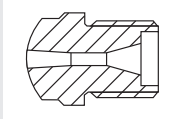
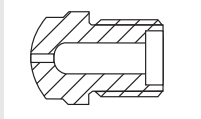

ABS & NRT : Opening mini : 3mm

### Tip length

- 38 mm (1)
- 70 mm (2)
- 95 mm (3)
- 127 mm (4)

Length 70, 95 & 127mm are not available in ABS version

### Radius

- 35 mm (8)
- 30 mm (R30)
- 19 mm (7)
- 15 mm (6)
- 12,7 mm (5)
- 10 mm (R10)
- 9 mm (9)
- 120° (4)
- 90° (3)
- 70° (1)
- 60° (2)
- Other



### Opening

- 1,5 mm (I)
- 2 mm (H)
- 2,5 mm (J)
- 3 mm (K)
- 4 mm (L)
- 5 mm (M)
- 5,5 mm (Q)
- 6 mm (N)
- 6,5 mm (R)
- 7 mm (S)
- 8 mm (O)
- 9,5 mm (P)
- Other

GP

1

6

K

Example: GP16K

Universal type (GP) - Tip length 38mm (1) - Radius 15mm (6) - Opening 3 mm (K)

# Standard Removable Tips



Standard Removable Tip Nozzle OEM  
Ensures reliable performance, easy replacement, and full compatibility with original equipment. Features Ø body 38 mm, probe hole on the flat, and 1/4"-28 NFT tightening.



Ø body 38 mm, probe hole on the flat, and 1/4"-28 NFT tightening for optimal compatibility and easy installation.

	Machine	Reference	Thread	Rear Opening (mm)	Thread length (mm)
<b>ARBURG</b>	80	ASS	24 x 1,5	8	30
	80	AX	24 x 1,5	8 ou 10	30
	A	AM	30 x 1,5	23,7	21
	A	ACB	35 x 2	18	28
	B	ACC	36 x 2	12, 18 & 22	35
		ACCD	36 x 2	24	33
	B	AH	45 x 1,5	25 & 30	34
	B	AB	45 x 2	22	36
	ø relief 41 or 42 mm	AD	45 x 2 left & right	25	36
	B	AE	45 x 2	30	36
	B	AV	50 x 2	30	36
	B	AG	50 x 2	35	36
	B	ACE	52 x 2	35	36
	B	AN	55 x 2	30	33
B	AI	55 x 2	40	36	
B	AL	60 x 2	45	36	
<b>WITTMAN</b>	50/20	GO	32 x 2	21	26
	A	BTG	35 x 2	12	28
	L/F to specify	BT	35 x 2	1/2"	40
	350	BTE	35 x 2	18, 22 & 25	27
	A	BM	35 x 2	20	25
	50, 300, 75HK, BSKM100	GP	35 x 2	21	25,4
	100, 160, 225,	BG	35 x 2	21	28
	650/300	BE	35 x 2	22	30
	BA230, Plus250, BSKM 45/20	GM	35 x 2	25	26
	C	BP	40 x 2	1/2"	50
	PLUS350	BTK	40 x 2	18	30
	A	BZZ	40 x 2	21	31
	BSKM400, 350	BB	40X2	25	28
	A	BTJ	40 x 2 LXF* 29	30	29,5
		BLC	45 x 2	25	25
	A	BX	45 x 2	34	30
	BSKM 750, 1200	BTL	65 x 3TR or M65 x 3	48	51
C	BL	65 x 3	2"	50	



# Standard Removable Tips



Standard Removable Tip Nozzle OEM  
Ensures reliable performance, easy replacement, and full compatibility with original equipment. Features Ø body 38 mm, probe hole on the flat, and 1/4"-28 NPT tightening.



	Machine	Reference	Thread	Rear Opening (mm)	Thread length (mm)
<b>BILLION</b>		BJA	24 x 2	8	33
	140T B	BJC	30 x 2	14 or 21	41
	A	BJB	35 x 15	27	27
	HI300/2000 B	BJE	36 x 2 conical seat	10	44
	HI295/300TP	BJX	40 x 2	20	42
		BJD	50 x 2	36	52
	C	BJI	60 x 3	25	36
	C	BJF	62 x 3	40	49
	C	BJG	65 x 3	25	63
	BIG	65 x 3	40	63	
<b>BOY</b>	15, 22, 30	BD	24 x 15	14	29
	A	BBE	30 x 15	14	30
	25M A	BBC	30 x 2	14	29
	50-80 A	BY	35 x 15	16	36
	50	BW	35 x 15	22	22
<b>DEMAG</b>		DND	24 x 15	8	30
	D55 1992 B	DL	33 x 2	20	30
	C	DNB	36 x 15	27	24
	C	DD	40 x 2	27	45
	New Ergo Tech	DO	40X3 left & right	8	38
	525 B	DB	45X3 LXF* 31 mm	25	31
	NGIII B	DJ	45X3 LXF* 44 mm	25	44
	A	DE	45 x 2	30	18
	New Pro	DNC	48 x 15	25	35
		DNE	48 x 3	32	35
	240 - 165/F C	DC	60 x 2	30	45
	B	DH	60 x 2	31	36
	Ergotech ET200-840175 D150 D210 D250 NCIII,NCL B	DN	60 x 3	25	36
	B	DG	60 x 3	31	36
	B	DM	60 x 3	32	40
D360 390 NCIII B	DK	60 x 3	40	40	
<b>ENGEL</b>	60T & 80T	EOT	26 x 15	14	22
	200/50	EU	28 x 15	8 or 12	33
	150T A	EOO	30 x 2	10 or 12	31

# Standard Removable Tips



Standard Removable Tip Nozzle OEM  
Ensures reliable performance, easy replacement, and full compatibility with original equipment. Features Ø body 38 mm, probe hole on the flat, and 1/4"-28 NPT tightening.



	Machine	Reference	Thread	Rear Opening (mm)	Thread length (mm)
<b>ENGEL</b>	A	EW	1-1x4"-9 BSF	7/8"	32
	A	EOE	1-1x4"-10	19	32
	7A B	EF	1-1x4" BSF	27	35
	25T/35T A	EON	1-3x8" Whitworth	21,5	26
		EOL	1-1x4"-10	1/2"	32
	A	ET	32 x 25	20	31
	A	EY	32 x 15	20	28
	ES50 A	EB	35 x 2	16	19
	A	EOH	35 x 2	22	28
	40/17 A	EN	36 x 15	22	26
	100T, ES300 100 A	EJ	40 x 2	24	32
	90 A	EI	40 x 2	26	23
	60/75 Ton A	EOC	40 x 2	27,5	23
	50/75 A	EK	40 x 2	25	25,4
	B	EV	40 x 3	30	34
	B	EM	45 x 2	16	39
	90/50	EP	45 x 2	27,5	25
	WSI300 200-250	EE	45 x 3	19	33
	90	ED	45 x 3	20	32
	350/150	EO	45 x 3	32	34
B	EOG	45 x 3	34	33	
A	EL	55 x 3	30	28	
ES 750/250 A	EC	55 x 3	32	26	
ES2000/350N C	EX	55 x 3	35	44	
650T B	EZ	64 x 2	42	35	
<b>FANUC</b>		FANA	24 x 2	13	22
		FANB	36 x 4	16	36,3
<b>HAITIAN</b>		HAC	M39 x 2	16 - 18 - 19	36
		HAZ	M45 x 4	20	60
<b>HUSKY</b>	C	HJ	45 x 3	22	45
<b>JSW</b>	350T	JTC	30 x 2	7,3	31
		JTG	30 x 2	15	44
	C	JB	50 x 3	10	55
	A	JD	50 x 3 Short Pilot	15	30
	C	JX	50 x 3 / 26 Pilot	15	55
	B	JG	55 x 3	8	40
	B	JE	55 x 3	20	37

# Standard Removable Tips



Standard Removable Tip Nozzle OEM  
Ensures reliable performance, easy replacement, and full compatibility with original equipment. Features Ø body 38 mm, probe hole on the flat, and 1/4"-28 NPT tightening.



	Machine	Reference	Thread	Rear Opening (mm)	Thread length (mm)
<b>KLOCKNER FERROMATIC</b>		KZZ	30 x 15	8	16
		KMD	30 x 15	9	16
		KMC	30 x 15	1/2"	16
	A	DE	45 x 2	30	18
	Klockner Milacron	KMI	48 x 3	32	27
	B	KY	58 x 3	35	44,5
	KMI50, 250, KM90 340B A	KE	48 x 3 Female	12	41
	KM65/220/C2	KNL	48 x 3 Male	32	35
	A	KN	55 x 3	33	40
	C	KNI	58 x 3	45	50
	B	KF	64 x 3 Female	12 (12.7)	44
	KHS80 C	KNK	65 x 3	50	58
	KHS120E KHS160 B	KG	70 x 3 Female	20	44
<b>DK</b>	75-100 125-200 290-410	DKA	24 x 15	9, 10 & 12	18
	400-600 675-1000 1600	DKB	30 x 2	12 & 14	24
	75-100 125-200 290-410	DKA	24 x 15	9, 10 & 12	18
	400-600 675-1000 1600	DKB	30 x 2	12 & 14	24
<b>NEGRI BOSSI</b>	V17-110	NZZ	30 x 15 or 16TPI	19	22
	V17-110	NZZU	30 x 15 or 16TPI Conical seat	19	22
		NHB	35 x 15	16	34
	25/40	NXB	40 x 2	20	27
		NP	40 x 2	27	40
	V22/175FA, 190, 210, 250TEC	NL	40 x 2	28	28
		NGZ	48 x 2	19	35
	40T	NHM	48 x 2	25	35
	25,4	NM	48 x 2	28	38
	60T	GC	52 x 25	28	40
	60T	NHD	52 x 3	19	40
	60T	NY	58 x 2	35	45
	NB80	NHF	58 x 3	30	45
	NB62 V Series	NHN	58 x 3	32	45
		NHD	58 x 3	32	40
NB62 V7 9FA	NH	58 x 3	38	38	

# Standard Removable Tips



Standard Removable Tip Nozzle OEM  
 Ensures reliable performance, easy replacement, and full compatibility with original equipment. Features Ø body 38 mm, probe hole on the flat, and 1/4"-28 NPT tightening.



	Machine	Reference	Thread	Rear Opening (mm)	Thread length (mm)
<b>NEGRI BOSSI</b>		NHD	58 x 3	32	40
	NB62 V7 9FA	NH	58 x 3	38	38
	345, 360	NE	64 x 2 LXF* 55	34	55
	100, 150TEC	NHT	64 x 2	35	57
	90T	NV	64 x 2	38	57
	210SV, B330 300T, 250, 260, 150TEC, 300TEC 350, 80, 400	NK	64 x 3 LXF* 41	34	38
	250SV, 300, 400, 400TEC	NKL	64 x 3 LXF* 60	34	57
	100, 80, 80SV	NHZ	64 x 3	35	57
	80, 80SV, 100 NBI50TEC	NHO	64 x 3	40	57
	400, 520, 550, 650, 700, 720, 800, 950	NHC	64 x 3	42	57
	NB700	NHCU	64 x 3 Conical seat	42	57
	80SV	NEL	64 x 3 61 LXF*	45	57
	NBI50TEC	NF	64 x 3	45	57
		NFU	64 x 3 Conical seat	45	57
		NFV	64 x 3	45	57
		NHE	70 x 2	38	64
		SJ	70 x 2	45	64
	100SV, 150, 210TEC	NHV	70 x 3	40	60
	100SV, 150, 150SV, 210TEC	NHH	70 x 3 63 LXF*	45	60
	100SV, 150, 150SV, 210TEC	NHW	70 x 3	52	60
NB 150T 1990	NIU	70 x 3 Flat seat 45 LXF*	55 Check R/O	45	
NBI30	NHG	74 x 2	55	57	
<b>NESTAL</b>	B	NFT	48 x 3	13	35
	75 B	NO	48 x 3	29	35
	140, 75 B	NU	48 x 3	32	35
	150, 300, 140T 83	NOZ	56 x 3	32	43
	140, 150, 300	NFE	56 x 3	42	38

# Standard Removable Tips



Standard Removable Tip Nozzle OEM  
Ensures reliable performance, easy replacement, and full compatibility with original equipment. Features Ø body 38 mm, probe hole on the flat, and 1/4"-28 NPT tightening.



	Machine	Reference	Thread	Rear Opening (mm)	Thread length (mm)
<b>NISSEI</b>	2A, 5A A	NJT	20 x 15	8	21
	A	NT	35 x 2 24 LXF*	20	24
	9A, 12A, 18A, 25A, 36A B	NG	40 x 2	20	37,5
	9A, 12A, 18A, 25A, 36A B	IC	40 x 2	30	39
	50A, 71A, 100A, FS250 B	NJC	50 x 2	25	41
	50A, 71A, 100A B	NJ	50 x 2	26	41
	140A, 200A C	ND	60 x 2	30	47
	280A, 420A D	IT	80 x 2	40	82,5
<b>SANDRETTO</b>	Micro vis dia. 24mm C	SBK	48 x 3	24	55
	New 8 series	SY	48 x 3	30	50
	Micro vis dia. 28mm	SBH	50 x 3	28	50
	Micro vis dia. 32mm	SBM	50 x 3	32	50
	C	SBG	50 x 3	32	50
		SIT	50 x 3	33	55
	New 8 series	SQ	50 x 3	35	50
	135T 95B Séries 7 170T	SK	50 x 3 Conical	35	50
	Micro vis dia. 36mm	SBI	50 x 3	36	53
	Séries 7 Serie 7GV 60/200 D	SP	55 x 3	40	50
	7 Serie 135	SBN	65 x 3	50	40
	D	SBD	76 x 3	60	70
Mega	SBP	85 x 3	55	75	
S7 D	SBC	85 x 3	70	85	
<b>SUMITOMO</b>	C360, 450, C560, C900, CI250 A	SZ	48 x 2	12	36
<b>TEDERIC</b>		TEA	M30 x 3	12	27
		TEB	M33 x 2	16	31
		TEC	M42 x 3	20	37
		TED	M56 x 3	25	43
		TEE	M56 x 3	35	43

# Standard Removable Tips



Standard Removable Tip Nozzle OEM  
 Ensures reliable performance, easy replacement, and full compatibility with original equipment. Features Ø body 38 mm, probe hole on the flat, and 1/4"-28 NPT tightening.



	Machine	Reference	Thread	Rear Opening (mm)	Thread length (mm)
<b>TOSHIBA</b>	EN150 I70T A	TZZ	36 x 15	10	21,5
<b>TOYO</b>	B	TM	42 x 3	24	35
<b>WOOJIN</b>	TE30, TE50	WOA	42 x 3	18	39
	TE30, TE50	WOB	42 x 3	22	39
	TE30, TE50	WOC	42 x 3	25	39
	TE110 ÷ TE450, TE110A5 ÷ TE450A5, TH50 ÷ TH450	WOD	40 x 2,5 R	15	38
		WOE	40 x 3	20	37
		WOF	36 x 2,5	14	35
		WOG	36 x 2,5	16	35
		WOH	36 x 2,5	18	35
		WOI	42 x 3	20	39
		WOJ	60 x 2,5	25	54
	WOK	27 x 1,5	15	25	

Available in different lengths for optimal adaptability.

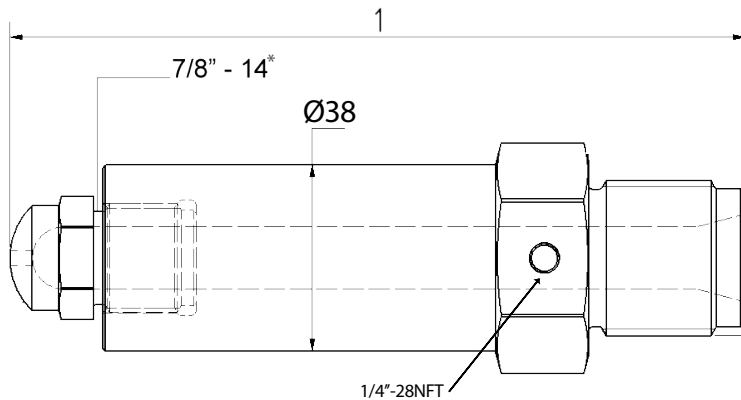

Ref	3	5	6	7	8	9	10	11	12
Length (l)	95	125	150	175	200	225	250	275	300

For example : EE5 = Nozzle Engel M45 x 3 OAL = 125mm

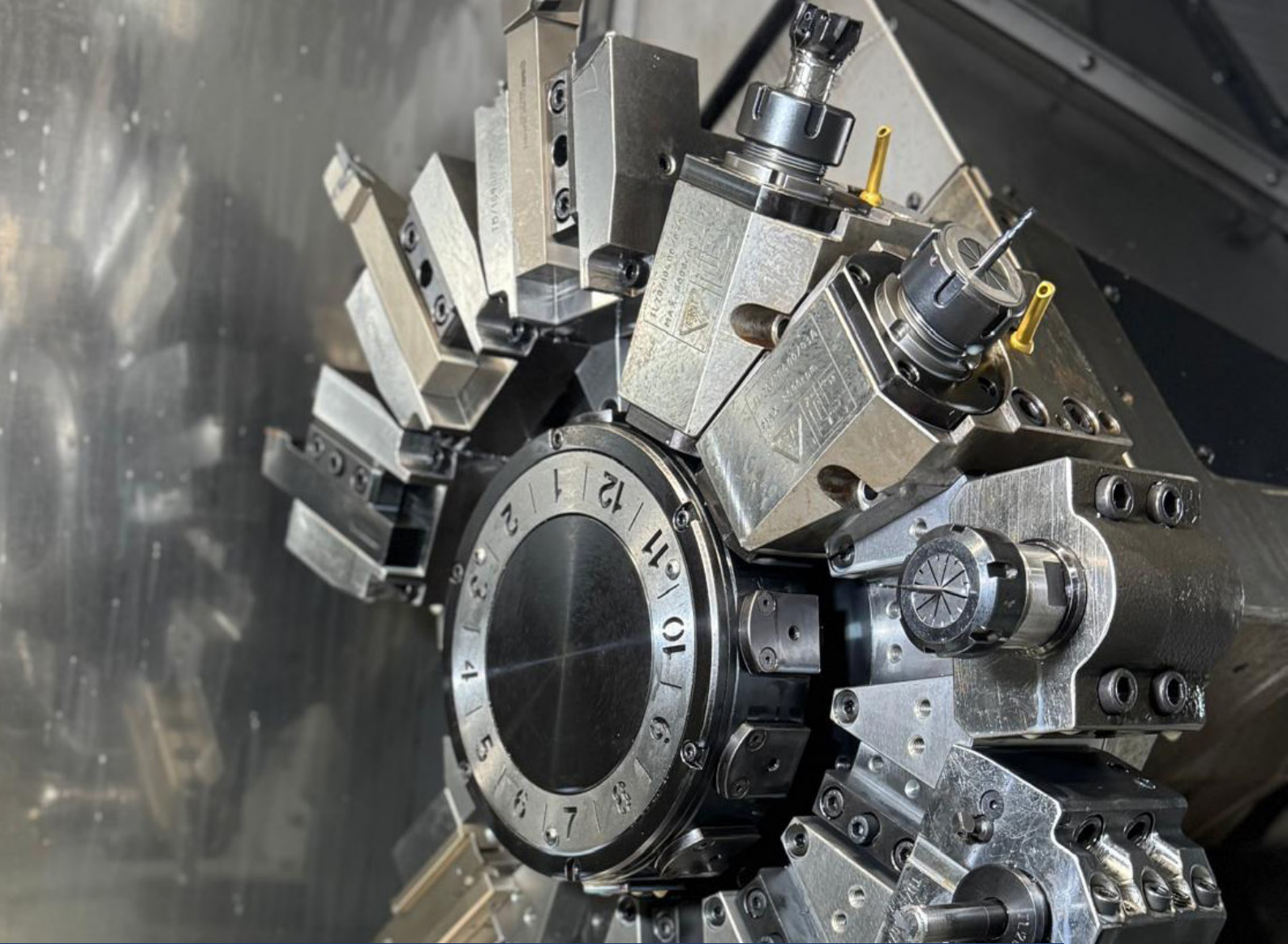

We manufacture nozzles and parts for your injection molding machines at our production site. Equipped with state-of-the-art CNC machining centers and lathes, we ensure precision and reliability at every stage. Our assembly and inspection teams guarantee strict quality control throughout the entire process. Special and urgent requirements are handled by our technicians all year round, without interruption.

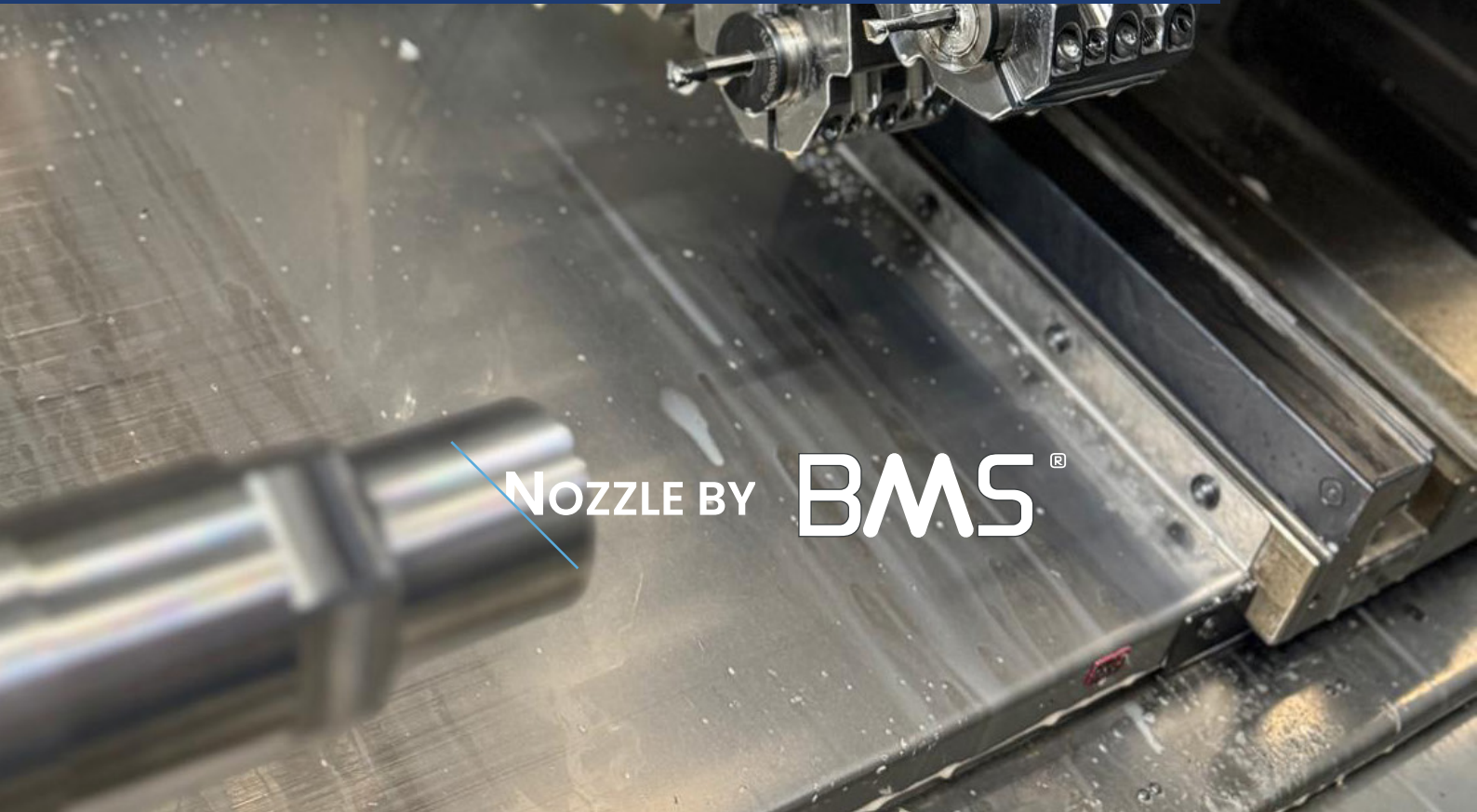

NOZZLE BY **BMS**<sup>®</sup>

## Internally heated nozzle

Significant savings compared to traditional monoblock nozzle  
 Replaceable tip nozzle with a machined rear thread to fit your machine and a standard 7/8"-14 female front thread to accept standard interchangeable tips.

Designed to replace monoblock nozzle: only replace the tip when it's damaged or when changing molds.  
 Precisely machined on CNC equipment and mirror-polished for optimal flow.  
 Nozzle are available in all lengths and can be supplied with 4 different tip lengths for applications with limited space.

Tips are also available in Cupro-Nickel for improved heat transfer.

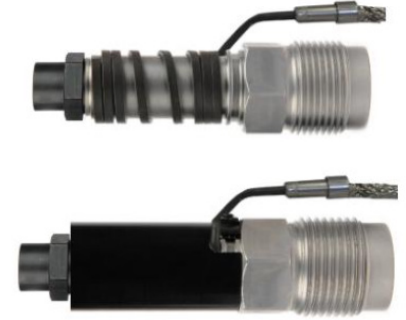

### The ideal solution for all high-temperature applications with immersion nozzle.

Designed for use on tooling (or any other application) where the center-to-center spacing is insufficient to allow for traditional heating elements such as band heaters.  
 Our nozzle are offered with spiral heaters and built-in thermocouples.

### Features

- Adjustable positioning of the outlet by 360°
- Burnished protective cover for optimal protection against corrosion
- Headless fixing screw with M5 pin: limited space requirement
- Nozzle entirely made of treated steel 110 kg or 48/52 Hrc on request

### Benefits

**No more heater bands**

**No more degradation issues due to material leakage**

**Faster return on investment**

**Higher heating power than standard bands = faster start-up**

**Built-in thermocouples**

### Resistance 4.2 x 2.2 with TC type J



Body length (mm)	Power (W)	Reference	Forming	Cover
30	250	0220350250TC	Ø30 x 20mm	CAP30
50	330	0220450330TC	Ø30 x 40mm	CAP50
75	620	0220800620TC	Ø30 x 65mm	CAP75
100	850	0221000850TC	Ø30 x 90mm	CAP100
125	1100	0221401100TC	Ø30 x 115mm	CAP125
150	1100	0221401100TC	Ø30 x 140mm	CAP150



# Internally heated nozzle

## Order form

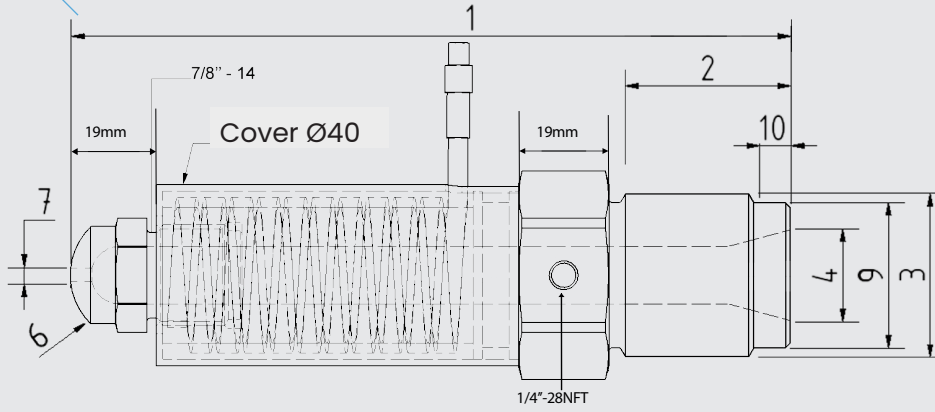
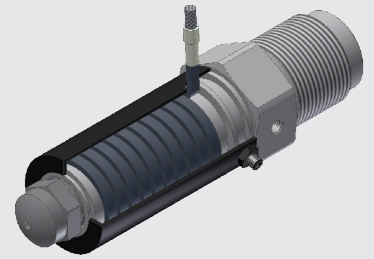

- Body length**
- |                                |                                |                                 |                                 |                                 |
|--------------------------------|--------------------------------|---------------------------------|---------------------------------|---------------------------------|
| <input type="checkbox"/> 30 mm | <input type="checkbox"/> 40 mm | <input type="checkbox"/> 50 mm  | <input type="checkbox"/> 60 mm  | <input type="checkbox"/> 70 mm  |
| <input type="checkbox"/> 80 mm | <input type="checkbox"/> 90 mm | <input type="checkbox"/> 100 mm | <input type="checkbox"/> 125 mm | <input type="checkbox"/> 150 mm |

Machine and Model

Injection rate  
in cm<sup>3</sup>/s

(1) Total length

(7) Opening (1.5, 2.5, 3, 4, ...)

(2) Thread Length

(8) Internal Design

(3) Thread Type

(M36x2 or 1"1/4-12UNF,...)

Universal (GP)

Polyamid (NRT)

ABS (ABS)

(4) Rear opening

(9) Ø relief

(6) Radius

(12,7mm, 15mm, 19mm, 35 mm...)

(10) Relief length

(8) Type

Universal (GP)

Polyamid (NRT)

ABS (ABS)

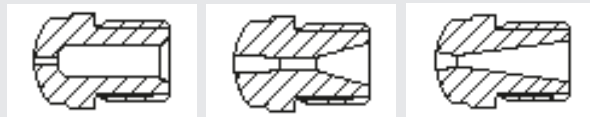

ABS & NRT : Opening mini : 3mm

Tip length

- 38 mm (1)
- 70 mm (2)
- 95 mm (3)
- 127 mm (4)

Length 70, 95 & 127mm are not available in ABS version

(6) Radius

- 35 mm (8)
- 30 mm (R30)
- 19 mm (7)
- 15 mm (6)
- 12,7 mm (5)
- 10 mm (R10)
- 9 mm (9)
- 120° (4)
- 90° (3)
- 70° (1)
- 60° (2)
- Other



(7) Opening

- 1,5 mm (I)
- 2 mm (H)
- 2,5 mm (J)
- 3 mm (K)
- 4 mm (L)
- 5 mm (M)
- 5,5 mm (Q)
- 6 mm (N)
- 6,5 mm (R)
- 7 mm (S)
- 8 mm (O)
- 9,5 mm (P)
- Other

GP

1

6

K

Example: GP16K

Universal type (GP) - Tip length 38mm (1) - Radius 15mm (6) - Opening 3 mm (K)

NOZZLE BY **BMS**<sup>®</sup>



The BMS static element mixing nozzle incorporates specific mixing elements called ISG (Interfacial surface generator). 4 to 6 stainless steel elements are inserted into a special bore.

Static mixing allows material to be blended without the use of moving parts. Plastic is propelled through the mixer, which homogenizes the material with minimal stress.

The two available systems consist of static elements with strong homogenizing capabilities.

They feature no moving parts and are easy to disassemble for cleaning. They can be equipped with filters or shut-off valves.



## Features

**No moving parts:  
Minimal wear,  
reduced maintenance**

**Homogeneous mixing:  
ISG elements ensure  
optimal material  
distribution**

**Durable design:  
High-strength steel,  
monolithic structure,  
easy to clean**

## What is static mixing?

Static mixing allows materials to be blended without the use of moving parts. The plastic is pushed through the mixer, which homogenizes the material with minimal stress.

## Purpose of a static mixer

To homogenize the mixture, meaning to create a uniform material that is consistent in all its components. Applications include thickness control for sheets and films, distribution and uniformity of cell size, tube walls, wires and cables, and other thickness-related issues.

The two available systems consist of static elements with high homogenizing efficiency. These nozzle have no moving parts and are easy to disassemble for cleaning. They can be equipped with filters or shut-off valves.

## 2 MODELS

### ISOMIX type mixing elements

p. 19



### XPS type mixing elements

p. 21



# Mixing nozzle - ISOMIX

The system consists of static mixing elements inserted into a specially machined nozzle body. There are no moving parts, and each element can be removed for cleaning. Each element is machined on its upper surface in such a way that, when assembled end-to-end, they form a chamber shaped like a tetrahedron.

Four diagonal holes are drilled into each element so that the material entering near the periphery exits at the center on the outlet face. Thanks to this unique concept, a set of 5 elements will generate 1,024 layers in the mixing process at the outlet point (4,096 layers with 6 elements).

This concept offers unmatched improvement over previous generations of mixers incorporating different types of mixing elements (which are more suitable for low-pressure injection applications).

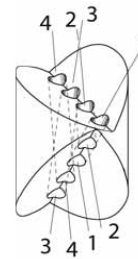

View of a mixing element

Number of layers generated in a mixing nozzle, depending on the number of elements

Mixing efficiency	1	2	3	4	5	6
Number of layers generated	4	16	64	256	1024	4096

Type	Number of elements	Elements Dia x Length (mm)	High viscosity (HDPE, ABS, filled PP)	Medium viscosity (GPPS, HIPS, PP MFI 1.5)	Low viscosity (PA PP LDPE)	Nozzle tip type
ISOMIXA	5	16 x 66,7	25 cm <sup>3</sup> /sec.	40 cm <sup>3</sup> /sec.	80 cm <sup>3</sup> /sec.	GP, NRT, ABS
ISOMIXB	6	16 x 82,6	25 cm <sup>3</sup> /sec.	40 cm <sup>3</sup> /sec.	80 cm <sup>3</sup> /sec.	GP, NRT, ABS
ISOMIXC	5	21 x 84,89	60 cm <sup>3</sup> /sec.	85 cm <sup>3</sup> /sec.	190 cm <sup>3</sup> /sec.	GP, NRT, ABS
ISOMIXD	6	21 x 103,10	60 cm <sup>3</sup> /sec.	85 cm <sup>3</sup> /sec.	190 cm <sup>3</sup> /sec.	GP, NRT, ABS
ISOMIXE	5	25 x 107,2	110 cm <sup>3</sup> /sec.	170 cm <sup>3</sup> /sec.	370 cm <sup>3</sup> /sec.	KN
ISOMIXF	6	25 x 132,6	110 cm <sup>3</sup> /sec.	170 cm <sup>3</sup> /sec.	370 cm <sup>3</sup> /sec.	KN

# Mixing nozzle - ISOMIX

## Order form

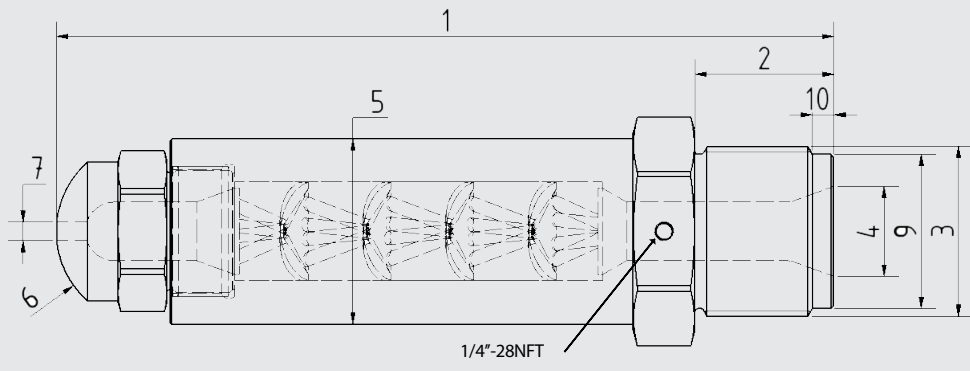
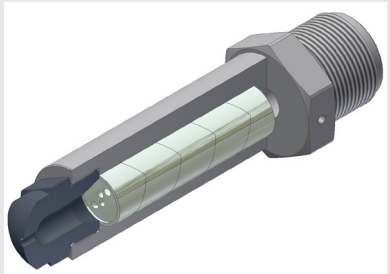

Machine and Model  Injection rate in cm<sup>3</sup>/s

(1) Total length  (7) Opening (1.5, 2.5, 3, 4, ....)

(2) Thread Length  (8) Internal Design

(3) Thread Type  (M36x2 or 1"1/4-12UNF,...)

(4) Rear opening  (9) Ø relief

(5) Body diameter (38, 50, ...)  (10) Relief length

(6) Radius  (12,7mm, 15mm, 19mm, 35 mm...)

(8) Type  Universal (GP)  Polyamid (NRT)  ABS (ABS)

ABS & NRT : Opening mini : 3mm

Tip length  38 mm (1)  70 mm (2)  95 mm (3)  127 mm (4)

Length 70, 95 & 127mm are not available in ABS version

(6) Radius  35 mm (8)  30 mm (R30)  19 mm (7)  15 mm (6)  12,7 mm (5)  10 mm (R10)  9 mm (9)  120° (4)  90° (3)  70° (1)  60° (2)  Other

(7) Opening  1,5 mm (I)  2 mm (H)  2,5 mm (J)  3 mm (K)  4 mm (L)  5 mm (M)  5,5 mm (Q)  6 mm (N)  6,5 mm (R)  7 mm (S)  8 mm (O)  9,5 mm (P)  Other

GP  1  6  K

Example: GP16K  
 Universal type (GP) - Tip length 38mm (1) - Radius 15mm (6) - Opening 3 mm (K)

# Mixing Nozzle – XPS

The XPS mixing nozzle has been specially designed to solve common mixing issues in injection molding, such as poor color dispersion, streaks, or material inconsistencies. Thanks to its optimized internal geometry, the nozzle ensures a homogeneous melt flow and excellent distribution of additives, masterbatches, and recycled materials. This results in improved part quality, reduced scrap, and higher process reliability – all while maintaining energy efficiency and ease of maintenance.

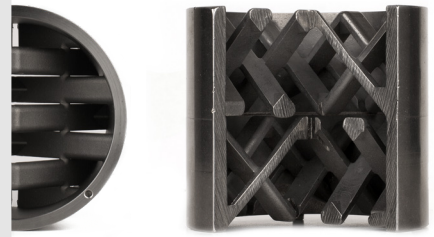

## Features

- Rows of interlaced bars inside a tube
- Bars are bonded to each other and to the tube -> solid structure
- Monolithic structure -> cast parts
- Grid edges form a roof shape – ensures smooth flow conditions
- Made from high-strength treated steel (17-4 PH), extremely durable
- Outer diameter and length (D, L) are machined and equipped with indexers



## Operating Principle

The flow passes through layers that are reorganized and forced to move in a radial direction. Adjacent mixing elements are offset by 90°, ensuring uniform distribution across the cross-section

Type	Mixing length (10 elements)	Dimensions – Inner dia x Outer dia	High viscosity	Low viscosity	Screw diameter (mm)	Nozzle type
XPS-I 18/12	79,9 mm	12 x 18 mm	400 cm <sup>3</sup> /sec.	600 cm <sup>3</sup> /sec.	max. 75	GP, NRT, ABS
XPS-I 28/18	109,9 mm	18 x 28 mm	750 cm <sup>3</sup> /sec.	950 cm <sup>3</sup> /sec.	max. 90	KN
XPS-I 34/24	139,9 mm	24 x 34 mm	1350 cm <sup>3</sup> /sec.	1900 cm <sup>3</sup> /sec.	max. 120	Adaptator + KN
XPS-I 42/32	179,9 mm	32 x 42 mm	3900 cm <sup>3</sup> /sec.	6100 cm <sup>3</sup> /sec.	max. 150	Adaptator + KN

# Mixing nozzle - XPS

## Order form

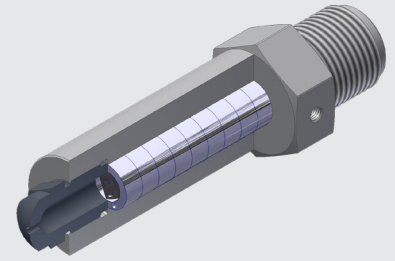
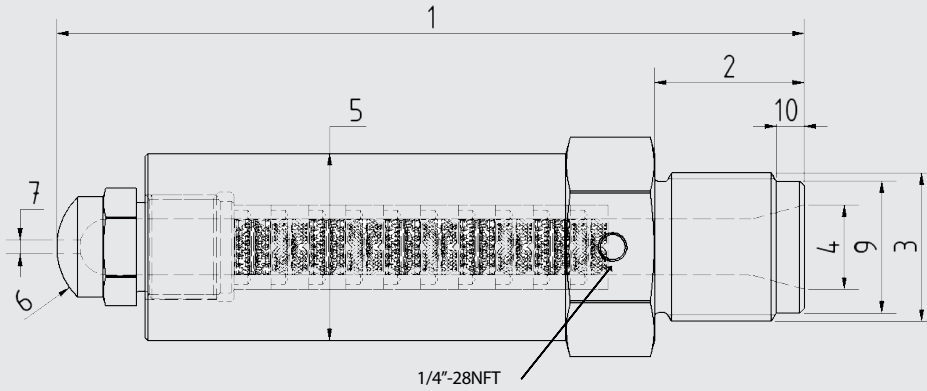

Machine and Model

Injection rate  
in cm<sup>3</sup>/s

(1) Total length

(7) Opening (1.5, 2.5, 3, 4, ...)

(2) Thread Length

(8) Internal Design

(3) Thread Type

(M36x2 or 1"1/4-12UNF,...)

- Universal (GP)  
 Polyamid (NRT)  
 ABS (ABS)

(4) Rear opening

(9) Ø relief

(5) Body diameter (38, 50, ...)

(10) Relief length

(6) Radius

(12,7mm, 15mm, 19mm, 35 mm...)

(8) Type

Universal (GP)

Polyamid (NRT)

ABS (ABS)

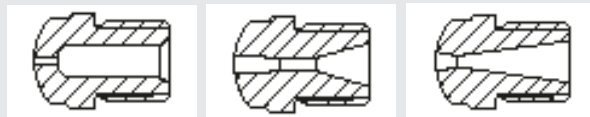

ABS & NRT : Opening mini : 3mm

Tip length

- 38 mm (1)  
 70 mm (2)  
 95 mm (3)  
 127 mm (4)

Length 70, 95 & 127mm are not available in ABS version

(6) Radius

- 35 mm (8)  
 30 mm (R30)  
 19 mm (7)  
 15 mm (6)  
 12,7 mm (5)  
 10 mm (R10)  
 9 mm (9)  
 120° (4)  
 90° (3)  
 70° (1)  
 60° (2)  
 Other



(7) Opening

- 1,5 mm (I)  
 2 mm (H)  
 2,5 mm (J)  
 3 mm (K)  
 4 mm (L)  
 5 mm (M)  
 5.5 mm (Q)  
 6 mm (N)  
 6.5 mm (R)  
 7 mm (S)  
 8 mm (O)  
 9,5 mm (P)  
 Other

GP

1

6

K

Example: GP16K

Universal type (GP) - Tip length 38mm (1) - Radius 15mm (6) - Opening 3 mm (K)



NOZZLE BY **BMS**<sup>®</sup>



Specifically designed for processors using regrind material that may be contaminated, or for production molds such as hot runner systems, where high-performance filtration is essential...  
Quickly eliminate any unmelted material or particles (metallic or otherwise) that could damage your hot runner blocks.



## Filtration Nozzle – TPF

p. 25

Forced-flow filters are designed with a blind hole into which the material is directly pushed, followed by a second hole positioned in the opposite direction, allowing the material to flow into the mold.



## Filtration Nozzle – BSEF

p. 27

High-strength treated elements.  
Specifically designed for high-performance filtration.



## Filtration Tips

p. 29

Hot runner molds and other production molds.  
Specifically designed for molders using potentially contaminated regrind material or production molds such as hot runners, where high-performance filtration is essential.



# Filtration nozzle – TPF

- Easy to remove and reposition for cleaning
- Provides excellent filtration for particles larger than 0.38 mm
- Large filter surface allows for extended molding runs before cleaning is required
- Filters available in high-strength versions for filled materials



## High-resistance filters for abrasive or filled materials

TPF1



TPF2



TPF3

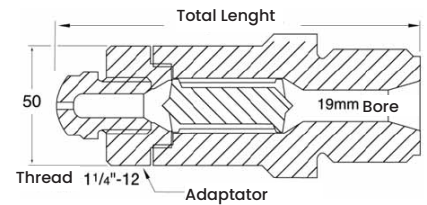
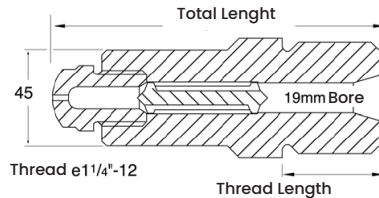
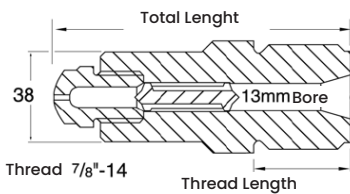

### TPF1

For low injection volumes  
Low-viscosity, unfilled materials  
Injectable volumes: less than 455 g  
Tip types: GP, NRT, ABS – 7/8"–14 thread

### TPF2

For medium injection volumes  
Low to medium-viscosity, unfilled materials  
Injectable volumes: less than 900 g  
Tip type: KN – 1 1/4"–12 thread

### TPF3

For high injection volumes  
Low to medium-viscosity, unfilled materials  
Injectable volumes: over 900 g  
Tip type: KN with adapter – 1 1/4"–12 thread

Standard Filter	High-Resistance Coating Filter	VAR Filter**	Element Length	Volume injection	Nozzle Tip
TPF1	TPFIT	TPFIV	38 mm	<450g	GP/NRT/ABS
TPF2	TPF2T	TPF2V	90 mm	<900g	KN
TPF3	TPF3T	TPF3V	150 mm	>900g	KN + adaptator

\* Compensation ring when the filter is removed

\*\* V.A.R. heat treatment for highly filled materials

# Filtration nozzle - Type TPF

## Order form

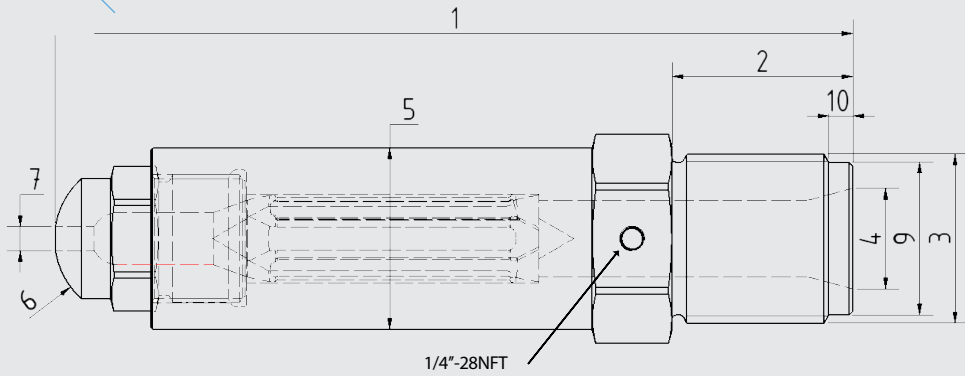
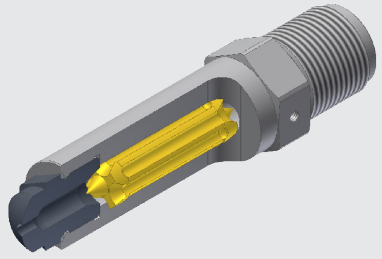

Machine and Model  Injection rate in cm<sup>3</sup>/s

(1) Total length  (7) Opening (1.5, 2.5, 3, 4, ....)

(2) Thread Length  (8) Internal Design

(3) Thread Type  (M36x2 or 1"1/4-12UNF,...)  Universal (GP)  
 Polyamid (NRT)  
 ABS (ABS)

(4) Rear opening  (9) Ø relief

(5) Body diameter (38, 50, ..)  (10) Relief length

(6) Radius  (12,7mm, 15mm, 19mm, 35 mm...)

### (8) Type

Universal (GP)

Polyamid (NRT)

ABS (ABS)

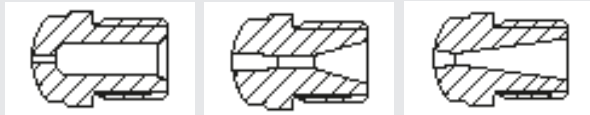

ABS & NRT : Opening mini : 3mm

### Tip length

- 38 mm (1)
- 70 mm (2)
- 95 mm (3)
- 127 mm (4)

Length 70, 95 & 127mm are not available in ABS version

### (6) Radius

- 35 mm (8)
- 30 mm (R30)
- 19 mm (7)
- 15 mm (6)
- 12,7 mm (5)
- 10 mm (R10)
- 9 mm (9)
- 120° (4)
- 90° (3)
- 70° (1)
- 60° (2)
- Other



### (7) Opening

- 1,5 mm (I)
- 2 mm (H)
- 2,5 mm (J)
- 3 mm (K)
- 4 mm (L)
- 5 mm (M)
- 5,5 mm (Q)
- 6 mm (N)
- 6,5 mm (R)
- 7 mm (S)
- 8 mm (O)
- 9,5 mm (P)
- Other

# Filtration nozzle – BSEF

The BSEF filtration nozzle from BMS are designed to optimize the injection molding process by ensuring a homogeneous melt flow free from impurities. With their robust construction and high-precision filter integration, they help reduce surface defects, extend mold lifetime, and minimize machine downtime caused by contamination. Available in various configurations, they provide a reliable solution for plastics processors looking to enhance both productivity and part quality.



## High-resistance filters for abrasive or filled materials

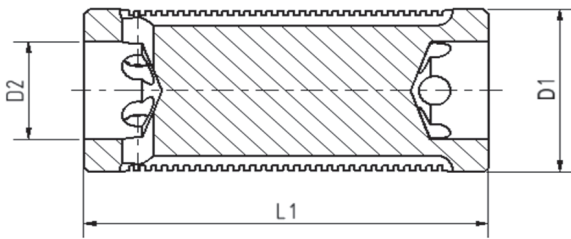

## Key Advantages

- Easy handling
- Low pressure loss
- Large flow area
- High-strength protection
- Flow passage from 0.6 to 1.2 mm
- CVD wear protected

Réf.	D1 (mm)	D2 (mm)	L1 (mm)	Passage (mm)	Surface totale de passage (mm <sup>2</sup> )	Débit d'injection (cm <sup>3</sup> /sec)	Perte de pression	Nozzle Tip
BSEF1	14	8	45	0,6	110	< 500	8 %	GP
BSEF108	14	8	45	0,8	160	< 500	6 %	GP
BSEF206	20	12	45	0,6	110	< 1000	8 %	GP
BSEF208	20	12	45	0,8	160	< 1000	6 %	GP
BSEF212	20	12	45	1,2	250	< 1000	4 %	GP
BSEF306	25	17	50	0,6	140	> 1000	8 %	KN
BSEF308	25	17	50	0,8	190	> 1000	6 %	KN
BSEF312	25	17	50	1,2	280	> 1000	4 %	KN

# Filtration nozzle - Type BSEF

## Order form

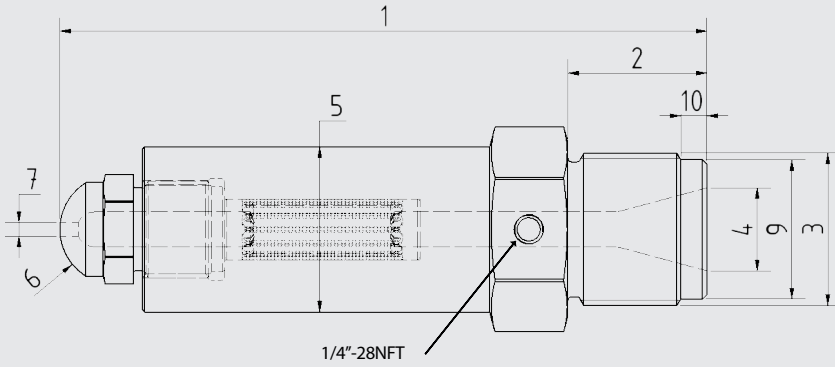
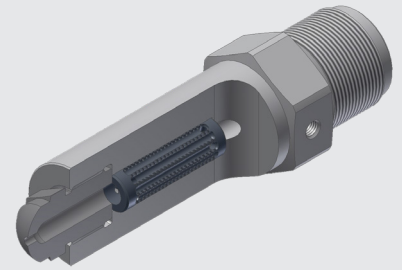

Machine and Model

Injection rate  
in cm<sup>3</sup>/s

(1) Total length

(7) Opening (1.5, 2.5, 3, 4, ...)

(2) Thread Length

(8) Internal Design

(3) Thread Type

(M36x2 or 1"1/4-12UNF,...)

Universal (GP)

Polyamid (NRT)

ABS (ABS)

(4) Rear opening

(9) Ø relief

(5) Body diameter (38, 50, ...)

(10) Relief length

(6) Radius

(12,7mm, 15mm, 19mm, 35 mm...)

(8) Type

Universal (GP)

Polyamid (NRT)

ABS (ABS)

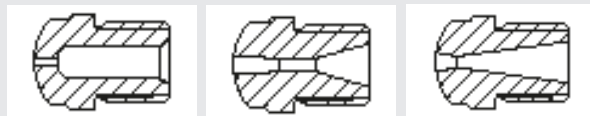

ABS & NRT : Opening mini : 3mm

Tip length

38 mm (1)

70 mm (2)

95 mm (3)

127 mm (4)

Length 70, 95 & 127mm are not available in ABS version

(6) Radius

35 mm (8)

30 mm (R30)

19 mm (7)

15 mm (6)

12,7 mm (5)

10 mm (R10)

9 mm (9)

120° (4)

90° (3)

70° (1)

60° (2)

Other

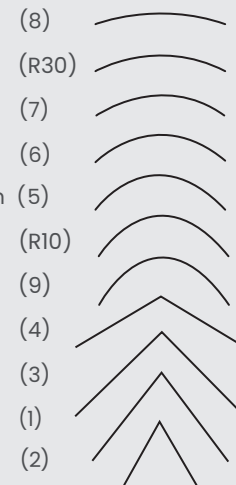

(7) Opening

1,5 mm (I)

2 mm (H)

2,5 mm (J)

3 mm (K)

4 mm (L)

5 mm (M)

5,5 mm (Q)

6 mm (N)

6,5 mm (R)

7 mm (S)

8 mm (O)

9,5 mm (P)

Other

GP

1

6

K

Example: GP16K

Universal type (GP) - Tip length 38mm (1) - Radius 15mm (6) - Opening 3 mm (K)

# Standard Filtration tips

An efficient and cost-effective system that aids in color dispersion with minimal pressure loss.

The disk is placed in the front or rear part of the nozzle, either directly behind the tip or just behind the nozzle body. It removes unmelted plastic particles and contaminants, and contributes to the overall dispersion of the material.

The NF disk is positioned in the rear section of the nozzle.



NF001

NF002

Ref.	Number of Holes	Diameter per Hole	Total Hole Area	Equivalent Orifice	Compatible Tips
NF001	49	0,6	13,9 mm <sup>2</sup>	4,2 mm	RGP, RNRT, RABS
NF002	37	0,8	18,6 mm <sup>2</sup>	4,9 mm	RGP, RNRT, RABS

## Mounting type

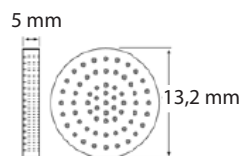
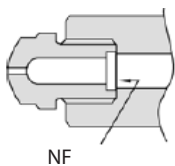

Length (mm)	Ref. type R	Profile	Thread	MBI Heater band	Nozzle wrench
38	RGP1	Universal	7/8-14	-	22
38	RNRT1	Nylon	7/8-14	-	22
38	RABS1	ABS	7/8-14	-	22
70	RGP2	Universal	7/8-14	MBI252010	27
70	RNRT2	Nylon	7/8-14	MBI252010	27
95	RGP3	Universal	7/8-14	MBI254010	27
95	RNRT3	Nylon	7/8-14	MBI254010	27
127	RGP4	Universal	7/8-14	MBI255010	27
127	RNRT4	Nylon	7/8-14	MBI255010	27

# Standard Filtration tips

## Order form

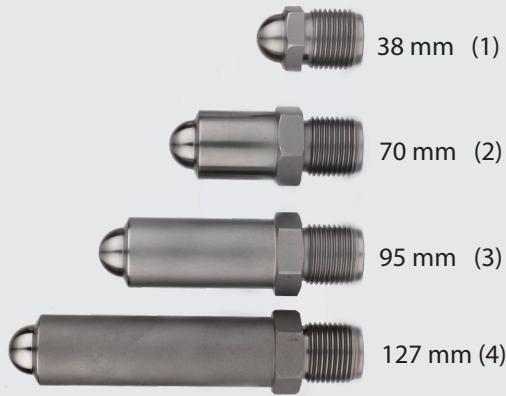

### Type

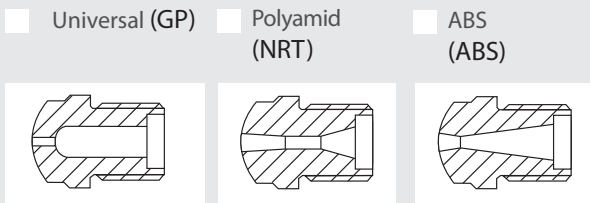

ABS & NRT : Opening mini : 3mm

### Tip length

- 38 mm (1)
- 70 mm (2)
- 95 mm (3)
- 127 mm (4)

Length 70, 95 & 127mm are not available in ABS version

### Radius

- 35 mm (8)
  - 30 mm (R30)
  - 19 mm (7)
  - 15 mm (6)
  - 12,7 mm (5)
  - 10 mm (R10)
  - 9 mm (9)
  - 120° (4)
  - 90° (3)
  - 70° (1)
  - 60° (2)
  - Other
- 

### Opening

- 1,5 mm (I)
- 2 mm (H)
- 2,5 mm (J)
- 3 mm (K)
- 4 mm (L)
- 5 mm (M)
- 5,5 mm (Q)
- 6 mm (N)
- 6,5 mm (R)
- 7 mm (S)
- 8 mm (O)
- 9,5 mm (P)
- Other

R*	GP	1	6	K
----	----	---	---	---

Example: RGP16K

\*with receipt for filter (R) - Universal type (GP) - Tip length 38mm (1) - Radius 15mm (6) - Opening 3 mm (K)

NOZZLE BY **BMS**<sup>®</sup>





Shut-off nozzle are generally used when processing low-viscosity polymers, or when it is necessary to retract the injection unit during the mould-opening phase. Precise and effective shut-off is the key feature of any type of shut-off nozzle.



## Benefits

**Optimized heat and flow transfer**

High throughput with minimal pressure loss and no material stress

**Compact and modular design cycle times**

Among the most compact nozzle on the market, with easy assembly/disassembly

**User-friendly maintenance**

Quick and easy cleaning, minimal production issues

**Flexible configuration**

One standard nozzle, adaptable with modular systems for every customer – most parts available from stock

## How to Choose Your Shut-Off Nozzle?

### 2 Possible Types

SEP Type  
With Cylinder

Type SES  
À ressort

SEP10  
500g/sec

SEP20  
1500g/sec

SEP30  
3500g/sec

SES10  
500g/sec

SES20  
1500g/sec

SES30  
3500g/sec

# Shut-Off Nozzle Type SES

The spring-loaded shut-off nozzle is used in processes involving low-viscosity materials such as PA, PP, PPS, PE, or POM. This nozzle is generally used in applications like packaging, and in sectors such as automotive, medical, and even electronics.



## SES Model – Versatile and Reliable

The SES series offers precision and efficiency in every operation. Available in Operation and Modular System versions, it adapts to your production needs, ensuring optimal performance and flexibility.

### SES10

**500 cm<sup>3</sup>/sec with PS**  
**Screw Diameter <30mm**  
**Max. Orifice: 4 mm**

### SES20

**1500 cm<sup>3</sup>/sec with PS**  
**Screw Diameter: 20–60 mm**  
**Max. Orifice: 7 mm**

### SES30

**3500 cm<sup>3</sup>/sec with PS**  
**Screw Diameter: 50–120 mm**  
**Max. Orifice: 11 mm**

## Operation

The shut-off needle moves axially inside the nozzle and is held in the closed position by the force of the spring.

The injection pressure (180 bars) pushes the assembly back. Once the injection is completed, the spring pushes the needle forward, closing the orifice. This unit is equipped with a high-temperature spring (500°C).



## Modular System

A specific adapter is made according to the needs of each user. However, the nozzle remains the same and is available in stock:

- Quick nozzle change
- Reduced delivery times
- Cost-effective solution

# Shut-off nozzle - Type SES

## Order form

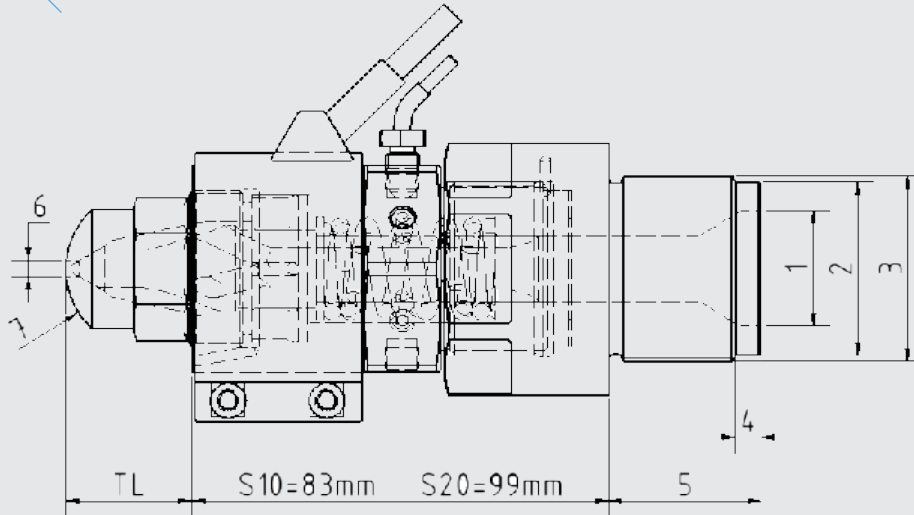
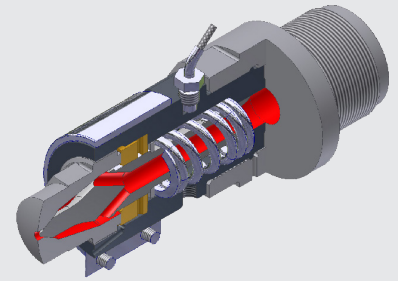

Machine and Model

(1) Rear opening

(5) Thread length

(2) Relief diameter

(6) Opening

(3) Thread adapter

(7) Radius

(4) Relief length

### Standard dimensions in mm

#### Nozzle Size

- S10 (for 500 cm<sup>3</sup>/sec with PS, opening max 4mm)
- S20 (for 1500 cm<sup>3</sup>/sec with PS, opening max 7mm)
- S30 (for 3700 cm<sup>3</sup>/sec with PS, opening max 11mm)

#### K= Tip length

- |     |   |                                     |                                     |
|-----|---|-------------------------------------|-------------------------------------|
| S10 | <input type="checkbox"/> TL= 20 mm (standard) | <input type="checkbox"/> TL= 55 mm  |                                     |
| S20 | <input type="checkbox"/> TL= 30 mm (standard) | <input type="checkbox"/> TL= 80 mm  | <input type="checkbox"/> TL= 120 mm |
| S30 | <input type="checkbox"/> TL= 55 mm (standard) | <input type="checkbox"/> TL= 120 mm | <input type="checkbox"/> TL= 200 mm |

- |   |   |
|---|---|
| <input type="checkbox"/> Pneumatic cylinder | <input type="checkbox"/> Hydraulic cylinder |
|---|---|

#### Option: Heater band

- S10 : Ø40 x 30 mm 200W 230V Lead 1m Ref: MBI353010
- S20 : Ø50 x 40 mm 300W 230V Lead 1m Ref: MBI453810
- S30 : Ø75 x 60 mm 715W 230V Lead 1m Ref: MBI706010



- Option: Thermocouple type J cable length 1.5 m M8x100 mm Ref: KNTC1



# Shut-Off Nozzle Type SEP

## SEP10

500 cm<sup>3</sup>/sec with PS  
Max. Orifice: 4 mm

## SEP20

1500 cm<sup>3</sup>/sec with PS  
Max. Orifice: 7 mm

## SEP30

3500 cm<sup>3</sup>/sec with PS  
Max. Orifice: 11 mm



## Operation

Unlike spring-loaded nozzle, P-type nozzle can be controlled at any time without any pressure loss. The opening and closing process is managed by a cylinder that can be actuated hydraulically or pneumatically. The cam position can be set at any point. This type of nozzle is equipped with a safety system allowing decompression above 600 bars.

Highly compact, these nozzle are adaptable to all types of presses. The cam can also be actuated by a coupling present on the machine or a cable system. The cylinder is controlled by the press controller.

## Types of Cylinders

Compact, integrated into the nozzle, separate.

In the «integrated» version, the cylinder is located below the nozzle. This compact design allows the mounting of this type of unit on any type of injection press. The power supply can be either hydraulic or pneumatic. The operating pressure is 6 to 10 bars for pneumatic systems and 50 to 70 bars for hydraulic systems.



## Cylinder Mounted on Press

This type of nozzle can also use the machine's cylinder.  
Contact our sales department.

## Modular System

A specific adapter is made according to each user's needs. However, the nozzle remains the same and is available in stock:

- Quick nozzle change
- Reduced delivery times
- Cost-effective solution

# Shut-off nozzle - Type SEP

## Order form

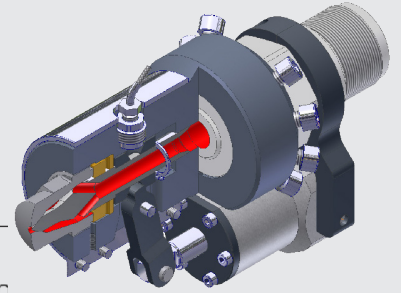
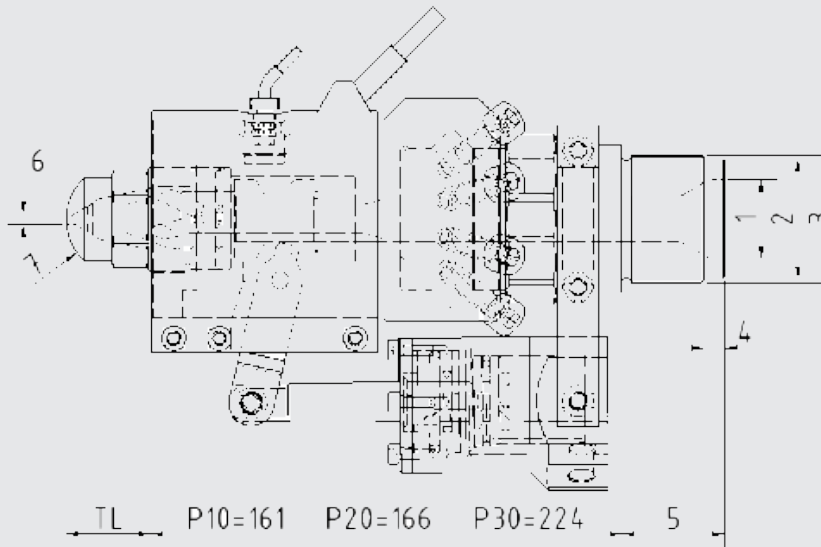

Machine and Model

(1) Rear opening

(5) Thread length

(2) Relief diameter

(6) Opening

(3) Thread adapter

(7) Radius

(4) Relief length

Standard dimensions in mm

Nozzle Size

- P10 (for 500 cm<sup>3</sup>/sec with PS, opening max 4mm)  
 P20 (for 1500 cm<sup>3</sup>/sec with PS, opening max 7mm)  
 P30 (for 3700 cm<sup>3</sup>/sec with PS, opening max 11mm)

K= Tip length

- P10  TL= 20 mm (standard)     TL= 55 mm  
P20  TL= 30 mm (standard)     TL= 80 mm     TL= 120 mm  
P30  TL= 55 mm (standard)     TL= 120 mm     TL= 200 mm

- Pneumatic cylinder     Hydraulic cylinder

Option: Heater band

- SEP10 : Ø60 x 75 mm 200W 230V Lead 1m Ref: 100 0114 5  
SEP20 : Ø20 x 70 mm 300W 230V Lead 1m Ref: 100 0044 5  
SEP30 : Ø90 x 110 mm 715W 230V Lead 1m Ref: 100 0117 5



Option: Thermocouple type J cable length 1.5 m M8x100 mm Ref: KNTC1



NOZZLE BY **BMS**<sup>®</sup>



Solid nozzle made from high-quality treated steel, fully compatible with original tips supplied by machine manufacturers.

For each order, please specify the radius and orifice of your nozzle according to the OEM (original equipment manufacturer) specifications.



## Type Arburg

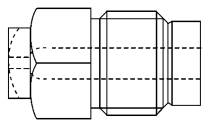

ASS2  
General Purpose

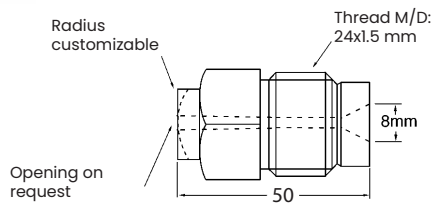

ASSN2  
Nylon Type

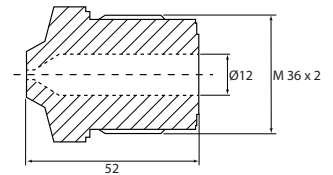

NSARI  
General Purpose

Adaptable on press types	General Purpose Tip Ref.	Nylon Tip Ref.	Length (mm)	Threading	Rear Opening (mm)
ARBURG	ASS2*	ASSN2*	50	M24 x 1,5 mm	8
ARBURG	ASS3*	ASSN3*	75	M24 x 1,5 mm	8
ARBURG	ASS4*	ASSN4*	95	M24 x 1,5 mm	8
ARBURG	NSARI*	-	52	M36 x 2 mm	12
ARBURG	NSAR3*	-	74	M36 x 2 mm	12

## Type Demag

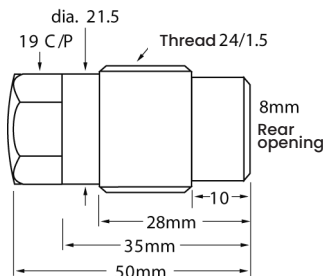

DNDS50

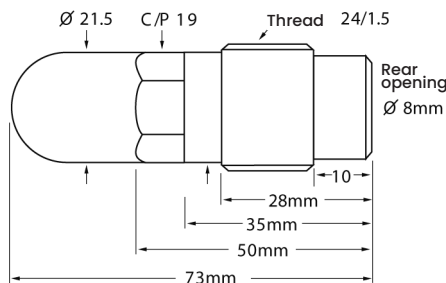

DNDS73

Adaptable on press types	General Purpose Tip Ref.	Nylon Tip Ref.	Length (mm)	Threading	Rear Opening (mm)
DEMAG	DNDS50*	-	50	M24 x 1,5 mm	8
DEMAG	DNDS73*	-	73	M24 x 1,5 mm	8
DEMAG	DNDS100*	-	100	M24 x 1,5 mm	8



## Type Engel

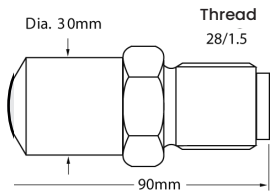

EU90

Adaptable on press types	General Purpose Tip Ref	Nylon Tip Ref.	Length (mm)	Threading	Rear Opening (mm)
ENGEL	EU90	-	90	M28 x 1,5 mm	8 or 12
ENGEL	EU125	-	125	M28 x 1,5 mm	8 or 12

## Type Fanuc

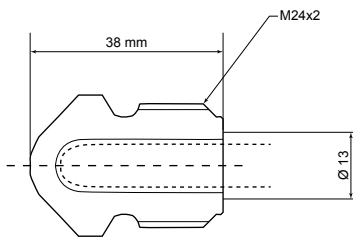

Adaptable on press types	General Purpose Tip Ref	Nylon Tip Ref.	Length (mm)	Threading	Rear Opening (mm)
FANUC	FU1*	-	38,4	M24 x 2 mm	13
FANUC	FU2*	-	70	M24 x 2 mm	13



# OEM Type Nozzles

## Order form



Arburg style



Demag style



Engel style



Fanuc style

Order Your Machine-Compatible Nozzle Tip









Create a reference using 3 criterias :  
Type, radius and opening.

Heat-treated 48–52 HRC for durability and reliable performance.

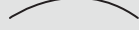
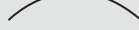
### (8) Type

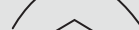
- ARBURG, General purpose  
ASS2, ASS3, ASS4, NSAR1, NSAR3
- ARBURG, Nylon cone  
ASSN2, ASSN3, ASSN4
- DEMAG  
DNDS50, DNDS73, DNDS100
- ENGEL  
EU90, EU125
- FANUC  
FU1, FU2

### (6) Radius

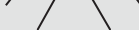
- 35 mm (8) 
- 30 mm (R30) 
- 19 mm (7) 
- 15 mm (6) 
- 12,7 mm (5) 
- 10 mm (R10) 
- 9 mm (9) 
- 120° (4) 
- 90° (3) 
- 70° (1) 
- 60° (2) 
- Other

### (7) Opening

- 1,5 mm (I)
- 2 mm (H)
- 2,5 mm (J)
- 3 mm (K)
- 4 mm (L)
- 5 mm (M)
- 5,5 mm (Q)
- 6 mm (N)
- 6,5 mm (R)
- 7 mm (S)
- 8 mm (O)
- 9,5 mm (P)
- Other

ASS2

3

K

Example: ASS23K

Nozzle type ARBURG (ASS2) - Radius 15mm (6) - Opening 3 mm (K)

Chrome-vanadium steel treated for extended service life.  
 Also available: sintered steels with ultra-high resistance (powder metallurgy technology), and copper-nickel alloys with high thermal conductivity (now available in a "hardened" version for longer lifespan).



## General Usage

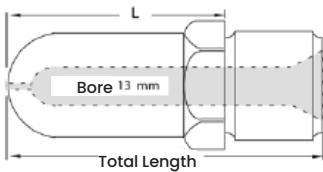

- Standard free-pass design.
- Minimal resistance to flow, minimal back pressure.
- Standard opening of  $\varnothing 12.7\text{mm}$  if no other specifications were given to us.

## Reverse cone Nylon Type

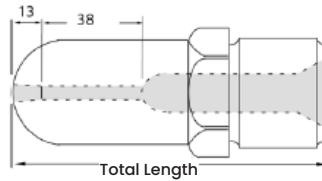

- Use: polyamides, acrylics and other expensive and heat-sensitive materials.
- The material flows over a length of 38mm through a channel with a diameter of 3mm, and then into an inverted cone with a length of 25mm. The sprue breaks off in the nose, reducing the risk of burr.

## With Full Cone – ABS Type

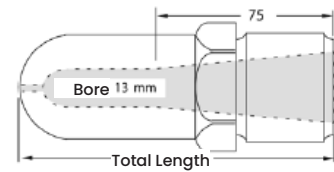

- For use with ABS, PVC and all other viscous materials.
- Reduces heat development and material build-up.
- We recommend using large openings to reduce the flow resistance. Cone 75mm long from rear opening, internal channel 12.7mm long.

# Solid nozzle

## Order form

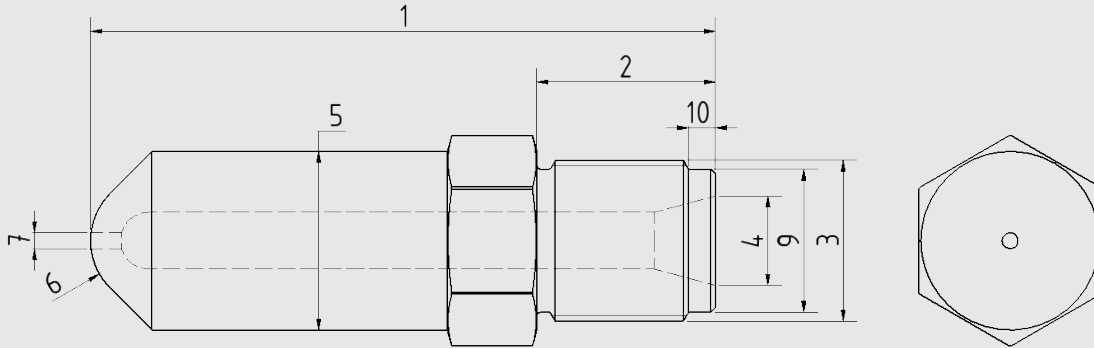
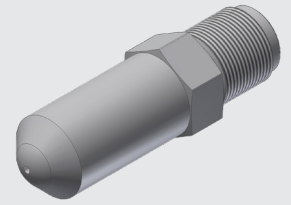

Machine and Model

Injection rate  
in cm<sup>3</sup>/s

(1) Length

(7) Opening (1.5, 2.5, 3, 4, ....)

(2) Thread Length

(8) Internal Design

- General Purpose  
 Nylon reverse taper  
 Full taper - ABS

(3) Thread Type

(M36x2 or 1"1/4-12UNF,...)

(9) Ø relief

(4) Rear opening

(10) Relief length

(5) Body diameter (25, 38, 50 mm)

(6) Radius

(12,7mm, 15mm, 19mm, 35 mm...)

All nozzle are polished with great care. These order forms are available for all our solid nozzle. We also do any type of nozzle with a plan.

## Adaptators

Small adaptators convert threads under 30 mm to standard 7/8"-14 threads. These adaptators allow the use of standard GP, NRT or ABS tips with 7/8"-14 threads, helping reduce costs and machine downtime while waiting for custom tips to be made.

Tips are made of treated steel and available in various radii, orifice shapes, and lengths from 19 to 130 mm (with extension). Extensions are ideal when space constraints are present.

A permanent stock ensures immediate shipping.

Note: OEM Type Nozzles with 24/1.5 mm thread and 8 mm rear opening are available in multiple lengths.



### Custom Adapters

Provide flexibility and reliability for your applications. Available in any diameter and length, adapters can be tailored to your exact requirements, ensuring perfect compatibility and performance.

**Easily standardize BMS nozzle on your existing injection molding machines**

# Adaptators Order form

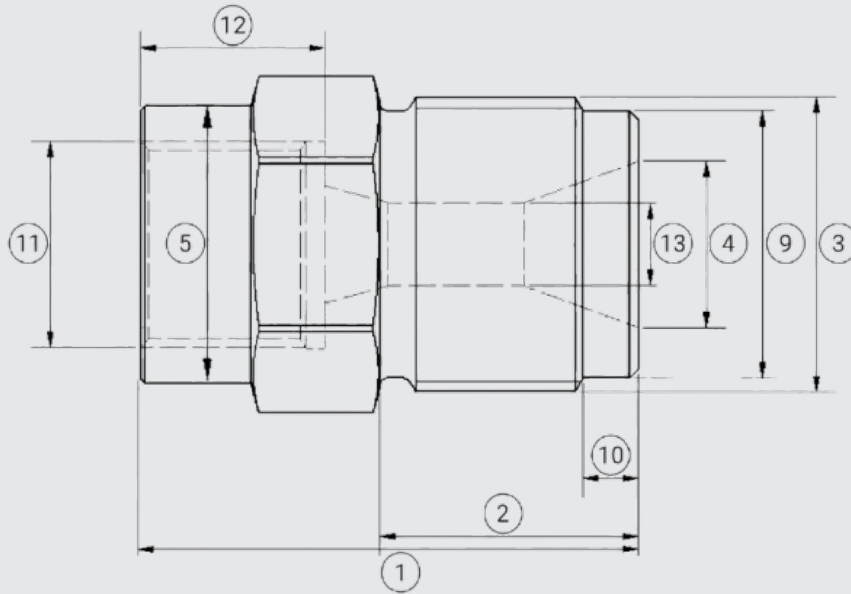
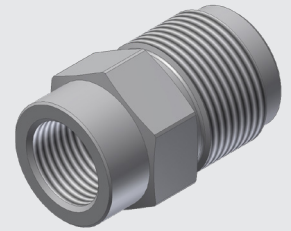

Machine and Model

Injection rate  
in cm<sup>3</sup>/s

(1) Length

(9) Ø relief

(2) Thread Length

(10) Relief length

(3) Thread Type

(M36x2 or 1"1/4-12UNF,...)

(11) Internal thread

(4) Rear opening

(12) Internal thread depth

(5) Nozzle Body

(38, 50 mm,...)

(13) Bore diameter (8 - 10 - 12 - 12.7)

# Material and running conditions

## Data sheet

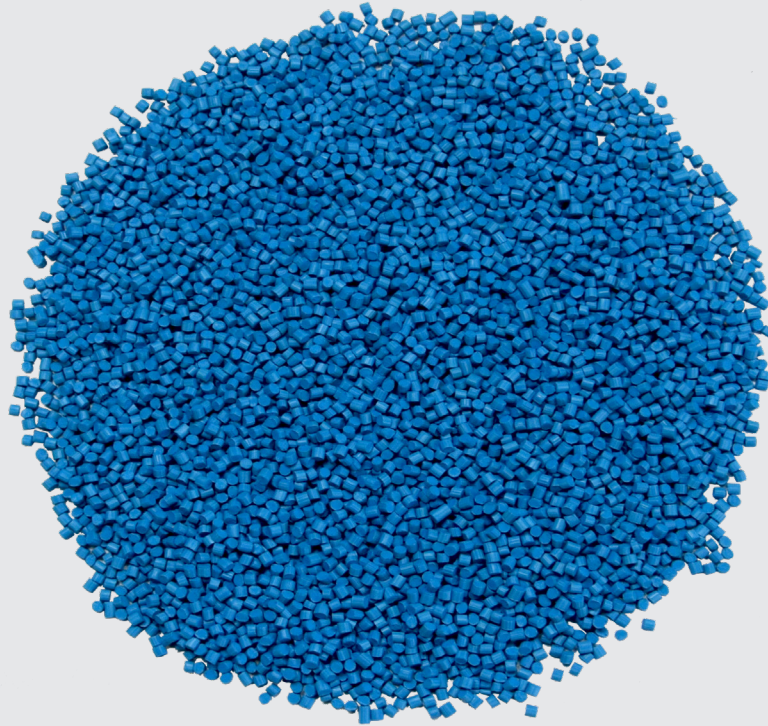

For any costing of your mixing nozzles, filling nozzles, filtering nozzles...  
All information relative to your working environment is essential for a good sizing

Machine and Model

Material information

Polymer Name  
(attach materiel sheet)

Measured at (°C)

MFI (melt Flow Index)

Producer

Rank

Operational conditions

Injectable volume (g)

Injection time  
(screw movement)

Injection temperature (°C)

Injection pressure (bars)

Name

Company

Email

Tel.

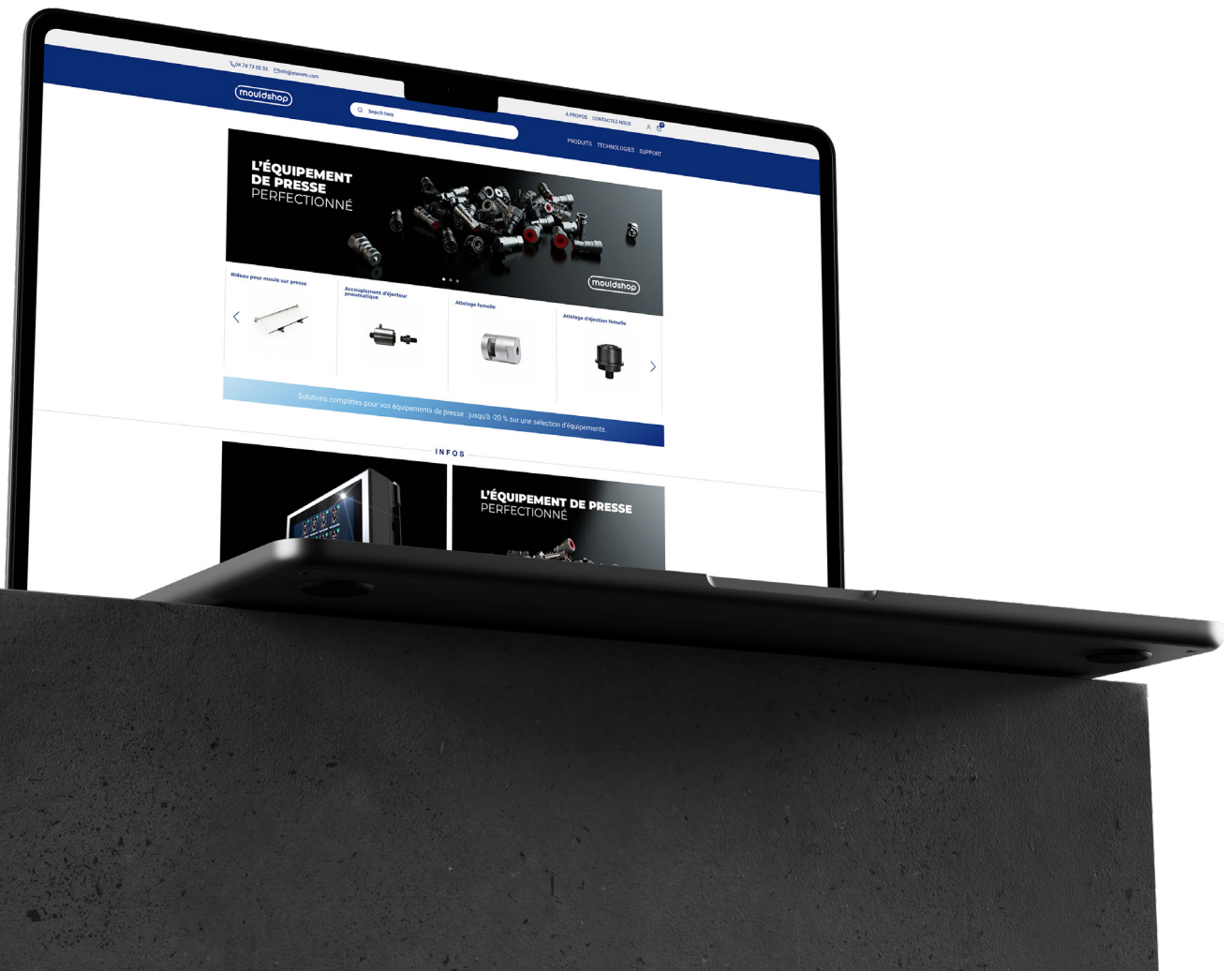



# Contact

Exclusively distributed through



If you need assistance or a personalized quotation, please do not hesitate to contact us.  
Our team is at your disposal to support you with your projects.

t: +33 4 50 27 29 00

[info@bmsfrance.eu](mailto:info@bmsfrance.eu)